



HUSKY
TOWING PRODUCTS

Weight Distribution Hitches

HUSKY CENTER LINE™ Towing System

The Center Line Torsion Weight Distribution Hitch and Active Sway Control System is the next generation in towing safety and performance.

The **Center Line** Torsion Weight Distribution and Sway Control System is the industry's first self centering sway control system, to provide you with complete confidence during your towing experience. Compression cylinder action and torsion spring bars work together to distribute weight and oppose trailer sway before it begins, keeping your trailer straight and on center, giving you increased control. The **Center Line** system can be used in all driving and weather conditions **including backing-up**. The "Easy Adjust" head alignment systems allow quick and easy set-up at the time of installation. The **Center Line** system is backed by a limited lifetime warranty for as long as you own the product (for complete warranty details visit www.huskytow.com/support.)

ADVANTAGES OF HUSKY'S CENTER LINE ACTIVE SWAY CONTROL TECHNOLOGY

- Compression cylinder design applies counter pressure to actively control trailer sway.
- Eliminates use of clamped friction materials.
- Provides constant pressure to re-center the trailer behind the tow vehicle.
- Can be used while backing up.
- Tapered torsion spring bars help transfer weight between all axles of the two vehicles for safe towing.
- Next Generation Patent Pending Technology.

The **Center Line** system overcomes many problems associated with the equalizing hitches and passive friction sway controls that have been in use for the past 30 years:

- No more removing the sway control when backing up! The **Center Line** system is *designed for your convenience*.
- No more waiting for the trailer to right itself as passing trucks, wind or road conditions cause sway. The **Center Line** system is *self-centering*.
- You don't have to hear our system to know it's working. The **Center Line** system's advanced technology *significantly reduces noise* common with old technology systems.



CENTER LINE Patent Pending

CENTER LINE HEAD ASSEMBLY KIT

Includes head assembly, spring bar brackets, 10" shank and hardware kit. Spring bars not included, required to complete hitch (see below).

Tongue Weight Range	Gross Trailer Weight	Part #
500–1,400 lbs.	4,000–14,000 lbs.	31390

CENTER LINE SPRING BARS ONLY

Match the spring bar rating to the trailer weight. Spring Bars have metallic gray textured finish. Sold in pairs.

Tongue Weight Range	Gross Trailer Weight ¹	Part #
500–800 lbs.	Up to 8,000 lbs.	31511
801–1,200 lbs.	Up to 12,000 lbs.	31512
1,001–1,400 lbs.	Up to 14,000 lbs.	31513

CENTER LINE SHANKS

Shank Length	Shank Rise	Shank Drop	Part #
10" Forged	7-1/2"	1/2"	31552
12"	7-1/2"	1/2"	30855
14"	7-1/2"	1/2"	30856
10"	10-3/4"	3-3/4"	30857
14"	10-3/4"	3-3/4"	30858
12"	13-1/4"	8-1/4"	30859

¹ SAFETY TIP: Do not use the Center Line Hitch with loaded trailers under 4000 lbs.

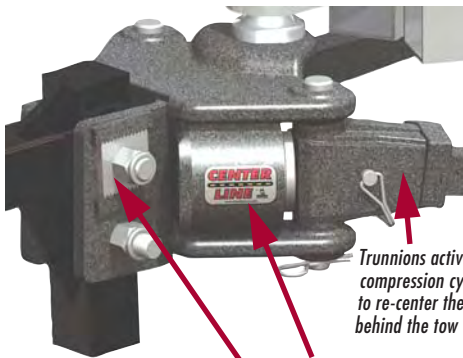

Trunnions activate the compression cylinders to re-center the trailer behind the tow vehicle.

Compression cylinder creates resistance to the sway.

The "Easy Adjust" head alignment systems allow quick and easy installation set-up.



Streamlined sturdy bracket design instead of chains for easier set-up.

Tapered torsion spring bar provides proper weight distribution.

HITCHES

ELECTRICAL

ACCESSORIES

RUNNING GEAR

PARTS/DISPLAYS

HUSKY INDEX

Weight Distribution Hitches

HUSKY
TOWING PRODUCTS



Weight distribution hitches evenly distribute weight over the entire length of tow vehicle and trailer, resulting in a more level ride with more control and stability, better braking, less strain on vehicle and increased towing capacity.



Without Weight Distribution



With Weight Distribution

WEIGHT DISTRIBUTION HITCH FEATURES

- Husky's hitch head design reduces installation time.
- Open hitch head design allows easy access to hitch ball shank.
- Hitch head features built-in sway control ball platform.
- Hitch head accepts different spring bar capacities for maximum versatility and reduced inventory.
- Black polyester finish resists rust and corrosion.

- Lift brackets allow safe and easy hitch hook-up.
 - Interchangeable spring bars fit left or right sides of hitch head.
 - Includes assembly hardware and chains.
 - Hitch ball not included. Be sure to match ball capacity to gross trailer weight.
 - Available with or without ball mount shank (#07660).
- See the Husky Parts pages for hitch replacement parts.

Round Bar Weight Distribution Hitch

Weight Distribution Hitch with Bolt-Together Ball Mount/Shank Assembly. Available with or without #07660 weight distributing shank.

- 8" total height adjustment. • Rise: 5-5/8"; Drop: 2-3/8". • Shank length: 10". • Ball to pin hole: 12-3/4". • Dual sway control platform.
- Raised ball platform for greater coupler clearance. • Balls not included; 1-1/4" hole on head assembly requires 1-1/4" shank on trailer ball.

****07036 requires a 2-1/2" receiver; do not exceed the vehicle's owners manual rating.**

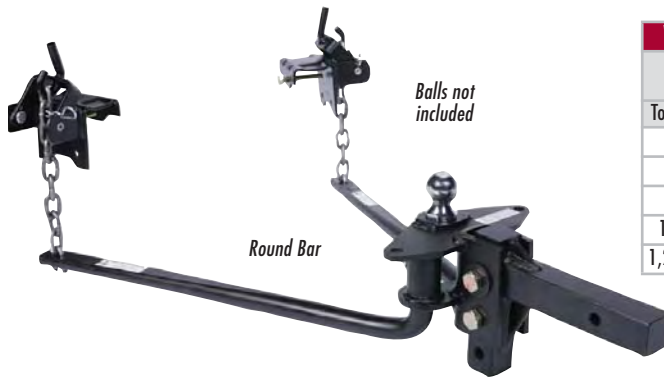

WEIGHT DISTRIBUTION HITCH, ROUND BAR: FULL SIZED TRAILERS

ROUND BAR		Complete Assembly (W/ Shank Assembly)	(Without Shank)
Tongue Wt. Range ‡	Gross Trailer Wt. ‡	Part #	Part #
400-600 lbs.	6,000 lbs.	31421	n/a
501-800 lbs.	8,000 lbs.	31422	31427
801-1,200 lbs.	12,000 lbs.	31423	31428
1,001-1,400 lbs.	14,000 lbs.	31425	n/a
1,201-1,700 lbs. **	15,000 lbs.	07036	n/a

Round Bar Weight Distribution Hitch Package

Weight Distribution Hitch with Bolt-Together Ball Mount/Shank Assembly and Sway Control. • 8" total height adjustment. • Rise: 5-5/8"; Drop: 2-3/8". • Shank length: 10". • Ball to pin hole: 12-3/4". • Dual sway control platform. • Raised ball platform for greater coupler clearance. • 1-1/4" hole on head assembly requires 1-1/4" shank on trailer ball.

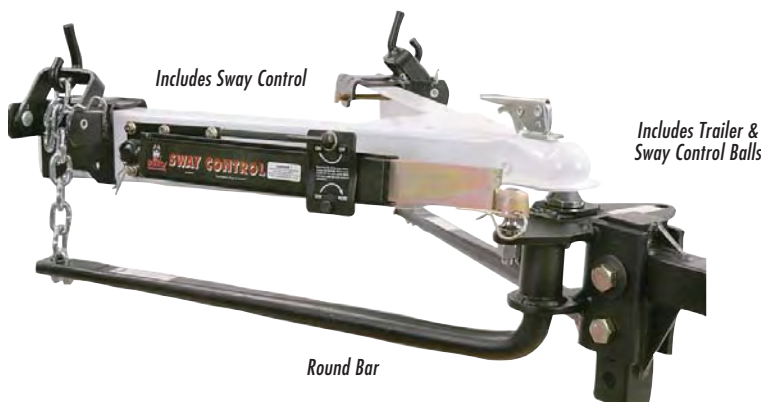

Package Contains the following:

- Weight Distribution Hitch rated up to 1,200 lb Tongue Weight Trailers
- Dual Friction Sway Control brake pad system to diminish sway from windy conditions and passing vehicles (recommended on trailers over 16 ft. in length)
- 2-5/16" Trailer Ball, pre-assembled to Weight Distribution Hitch
- Sway Control Ball included, but not pre-assembled.

Ready for Safe Towing out of the box!

Description	Part #
WD Hitch & 1 Sway Control Package, 1200 lb.	30849



HUSKY
TOWING PRODUCTS

Weight Distribution Hitches

HITCHES

ELECTRICAL

ACCESSORIES

RUNNING GEAR

PARTS/DISPLAYS

HUSKY INDEX

Trunnion Bar Weight Distribution Hitch

Bolt-Together Hitch Head/Shank Assembly. • Fits Class III / IV 2" receivers • Bolt-together head with 8" of height adjustment • Black baked-on polyester powder-coat finish for superior rust protection • 5-year limited warranty. • 8" total height adjustment. • Rise: 7-1/2"; Drop: 1/2". • Shank length: 10". • Ball to pin hole: 12". • Balls not included; 1-1/4" hole on head assembly requires 1-1/4" shank on trailer ball.



Pin Trunnion

WEIGHT DISTRIBUTION HITCH, TRUNNION BAR: FULL SIZED TRAILERS

PIN TRUNNION BAR		Complete (W/ Shank Assy.)	
Tongue Wt. Range‡	Gross Trailer Wt.‡	Part #	
300-500 lbs.	5,000 lbs.	07026	*
300-500 lbs.	5,000 lbs.	07027	**
501-800 lbs.	8,000 lbs.	31331	
801-1,200 lbs.	12,000 lbs.	31335	

* With offset snap up brackets. ** 6-1/2" total height adjustment, rise 4-3/4", drop 1-3/4", shank length 8-3/8", ball to pin hole 12-1/4".

‡ Limited to Vehicle Tow Rating; see Vehicle owners Manual.

PIN TRUNNION FEATURES: **A** Raised ball platform for greater coupler clearance, turning radius, access to trailer ball nut. Only 4" of ground clearance required to insert spring bars into pin trunnions. **B** Built-in dual sway control platform allows the use of either left or right sway control. When towing trailers longer than 24 feet, a second sway control should be added. **C** Spring bars are easily removed from pin trunnions with safety D-clips. Pin trunnions remain attached to head. **D** Unique pin trunnions attach to head using Grade 5 bolts instead of the standard knuckles. No need to remove pins so head stays clean and free of grease.

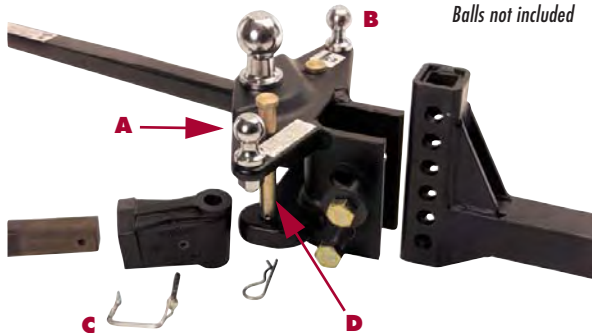

Balls not included



07005

Trunnion Bar Hitch Accessories

	Part #
Offset Snap-Up Bracket Assembly (Ideal for light duty WDH 07027; for use on tent trailers with swivel jacks; single unit with lift bracket)	07005
Safety D-Clip (C)	30125

Weight Distribution Hitch Chain Lift Kit

HUSKY CHAIN-LIFT BRACKET SERVICE KIT: Used to replace weight-distributing hitch's broken or damaged chain-lift units. Supports trunnion or round bar 500-1200 lb. spring bars. Boxed kit includes two lift brackets, two mounting bolts and two spring clips. Works with either trunnion style or round-bar weight distribution hitches from Husky and other brands, including Jayco Jay Flight models and other hard to fit applications. Finished with a baked-on black polyester powder-coat.

Description	Part #
Chain Lift Bracket Service Kit	31260
LS Chain Service Kit, 11 Link	30698



Weight Distribution Hitches

HUSKY
TOWING PRODUCTS



Sway Control

- Dual friction brake pad system provides constant and adjustable sway reduction.
 - Diminishes sway from windy conditions & passing vehicles.
 - Secures with socket & spring clip connectors.
 - Detaches quickly for storage.
 - Right-handed & left-handed models.
- NOTE: for trailers 24' and longer, the use of both Right Hand and Left Hand sway controls is recommended.

Description	Part #
Sway Control, RH, Packaged	34715
Sway Control, LH, Packaged	37498
Sway Control Parts & Accessories	
Weld-on Ball Mount Bar	34845
Replacement Slide Bar	34846
LS Replacement Friction Plate	34849
Replacement Crank Handle	34847
Replacement Tongue Ball Plate	34842
Replacement Spring Clip, 1/2", Bulk	34853
Sway Control Ball, 1-1/4"	33842
Ball Mount Adapter, Boxed	39585
Replacement Screws, Pkg/8	71195
Clamp-On Sway Control Ball Kit (for no-drill applications; fits frames up to 6")	38964

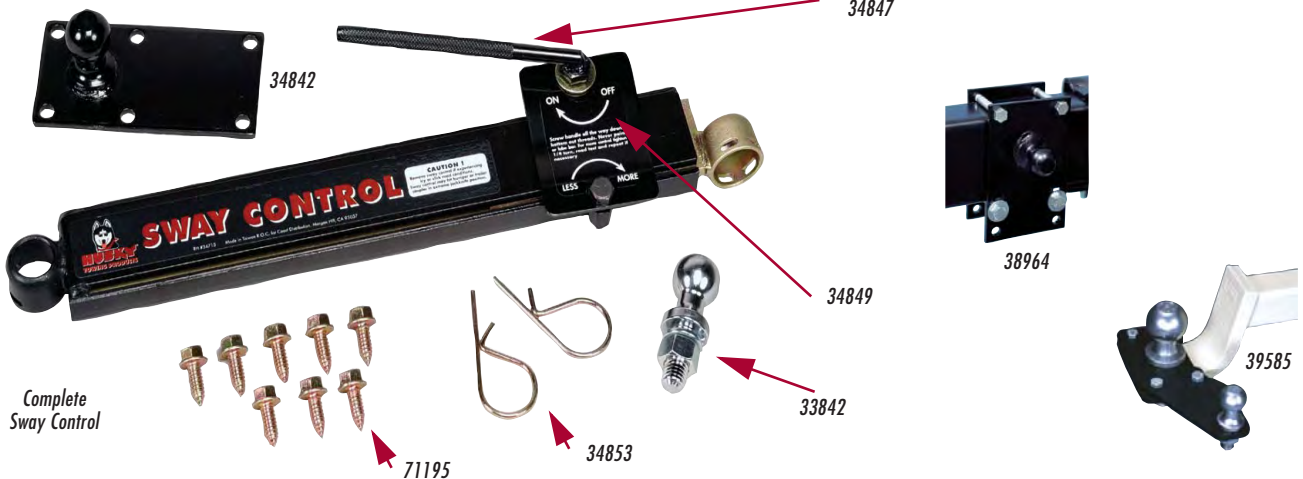

Weight Distribution Hitch Shanks

Bolt-Together Shank Only							Part #
Shank Length	Length (Ball hole to Pin Hole)		Rise		Drop		Bolted Shank
	Round	Trunnion	Round	Trunnion	Round	Trunnion	
*10" Standard	12-3/4"	12"	6-1/2"	7-1/2"	2-1/2"	1/2"	31518
10" Forged	12-3/4"	12"	6-1/2"	7-1/2"	2-1/2"	1/2"	31552
12" Standard	12"	13-7/8"	6-1/2"	7-1/2"	2-1/2"	1/2"	30855
14" Standard	14"	16"	6-1/2"	7-1/2"	2-1/2"	1/2"	30856
10" Standard	10"	11-7/8"	9-3/4"	10-3/4"	5"	3-3/4"	30857
14" Standard	14"	15-7/8"	9-3/4"	10-3/4"	5"	3-3/4"	30858
12" Standard	12"	14"	13-1/2"	13-1/4"	9-3/4"	8-1/4"	30859

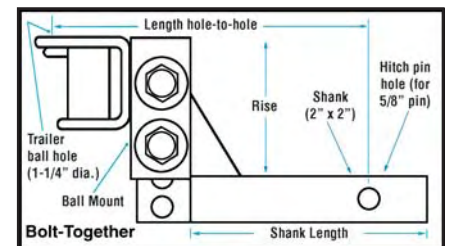
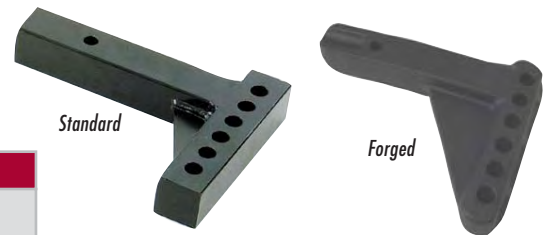

* Included with bolt on Weight Distributing Hitch



HUSKY
TOWING PRODUCTS

Gooseneck Hitches

HITCHES

Fixed Ball Platform Gooseneck Hitch

Husky's Gooseneck Trailer Hitch Ball Platform is used to tow trailers that use a gooseneck coupler such as livestock trailers and farm equipment trailers. These hitches feature safety chain attachments and 2-5/16" ball. *Base rails required; purchase separately.*



Description	Part #
25,000 lb. Capacity† Gooseneck Hitch without Base Rail	31368
Custom Base Rails (requires Custom Bracket Kit (page 717) or 31563, below)	31323
Universal Install Kit	31563

†Limited to Vehicle Tow Rating; see Vehicle owners Manual.

ELECTRICAL

NEW! Husky Folding Ball Gooseneck Hitch

Keep the bed of your truck free for any use with this versatile cam-over locking ball plate. Stores in place, allowing it to drop under the bed of your truck, leaving the bed free of obstructions. 2-5/16" installed hitch ball, 25,000 lbs. Gross Trailer Weight, 5,000 lbs Tongue Weight. Safety chain openings included. Hitch requires a hole to be cut in the bed of the truck; see the installation instructions. Installation kit required; it can be fabricated by the installer. *Do not exceed towing capacity of the tow vehicle*

ACCESSORIES



Description	Part #
Folding Ball Gooseneck Hitch	31821
Gooseneck Hole Cover, Bulk (plugs hole in your pickup bed when you remove hitch)	38959

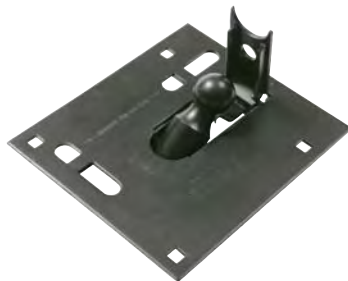

RUNNING GEAR

Stow-A-Fifth Wheel Adapter

Change from Gooseneck trailer towing to Fifth Wheel trailer towing in minutes. For use with Husky 15K, 16K & 20K hitches. Can also be used with the Fifth Wheel EZ Roller. Note: a complete Stow-A-Fifth Wheel requires both the Adapter plus a Bed Support Kit. Order separately.

PARTS/DISPLAYS

Description	Part #
Stow-A-Fifth Wheel Adapter for Stow-a-Gooseneck applications, without Bed Support Kit (Limited Supply)	07088
Stow-A-Fifth Wheel Adapter for B&W applications, without Bed Support Kit (Limited Supply)	070881
Bed Support Kit, fits 99-09 Chevy Silverado & GMC Sierra, Classic 2500 HD/3500 HD, New 2500HD & 3500	07078
Bed Support Kit, fits 03-09 Dodge Ram 2500/3500 HD	07079



HUSKY INDEX

Fifth Wheel Hitches

HUSKY
TOWING PRODUCTS



Husky Tilt Plate 16K S Straight Jaw Fifth Wheel Hitch (Husky Silver Series)

Husky 16K S Tilt Plate Design Advantages:

- Addition of a pop out safety hookup indicator
- Engineered/designed tolerances for less noise
- Better fit of components for consistent performance and a quieter ride
- Fore and aft adjustment on the uprights for proper "hitch over axle" placement
- Unlike some slide bar style hitches, the sides of the 16K S are open and allow the king pin to swing without hitting the sides of the head
- Meets or exceeds SAE J2638 fifth wheel standards
- Superior finish
- Yellow zinc fasteners
- Compatible with all Husky custom install kits and earlier model X-16 Husky hitches



The 4-way side to side, front to rear pivoting tilt plate provides easy hookup in most situations. The locking mechanisms in tilt plate hitches do not tilt with the head; they remain stationary while only the king pin and tilt plate move.

16K S Features

Red indicates 16K S jaw in open position

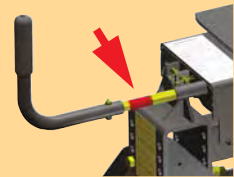





Green indicates jaw in closed position. Visible indicator pin on 16K S verifies king pin is engaged

Husky 16K S Tilt Plate Fifth Wheel Hitch (Straight Jaw)

Product	Use with all Fifth Wheels up to*	Jaw Style	Pop-out Indicator	Fore/Aft Adjustment	Warranty **
Husky 16K S	16,000 lbs.	Straight	Yes	2 Position	5 years

**Do not exceed vehicle manufacturer weight capacity.
**See www.huskytow.com for warranty details.*

Husky Silver Series Select-A-Hitch, as easy as 1-2-3

HITCH TYPE	STEP 1: HEAD		STEP 2: TOW VEHICLE		STEP 3: BASE RAIL		
	Head + Cross Member (Silver)	+	Short Bed	OR	Long Bed	+	Rail Only (Black)
	Part #		Roller # (Black)		Uprights # (Silver)		Part # (1)
HUSKY TILT-PLATE MODEL (STRAIGHT JAW)							
16K S	 31313	+	 07046	OR	 31314	+	 31323

(1) Installation Kits sold separately (see page 717). Husky offers vehicle specific install kits with universal or limited drill installations.



HUSKY
TOWING PRODUCTS

Fifth Wheel Hitches

HITCHES

ELECTRICAL

ACCESSORIES

RUNNING GEAR

PARTS/DISPLAYS

HUSKY INDEX

Husky Full-Feature Articulating Head Wrap-Around Jaw Fifth Wheel Hitch

Husky Full-Featured Articulating Head Design Advantages

- Improved pop out safety hookup indicator
- Handle moved forward, further from the king pin box
- Foam grip handle for easier operation
- Self locking and release handle
- No need to manually open the jaw to hitch up
- Patent-pending Anti-Walk wrap around jaw
- Engineered/ designed tolerances for less noise
- Better fit of components
- Fully articulating head (the jaw moves with the head)
- Fore and aft adjustment on the uprights for proper "hitch over axle placement"
- Improved cross member with castle nut
- Meets or exceeds SAE J2638 fifth wheel standards
- Radius added to the top plate for rugged appearance
- Superior finish
- Yellow zinc fasteners
- Compatible with all Husky custom install kits and earlier model Husky hitches

- MORE FEATURES in a sleek Husky design
- LARGE SELECTION of no-drill/limited drill applications
- 4-BOLT installation instead of 8 for other brands
- Weight ratings that meet the needs of the RV industry
- Only line of fifth wheel hitches with fore & aft upright adjustment
- Safety hook-up indicator on all models
- Very competitive pricing
- Less inventory investment required

Husky Silver Series



Full Featured 16K W & 26K W Features

On the full-featured series, red indicates the jaw is open

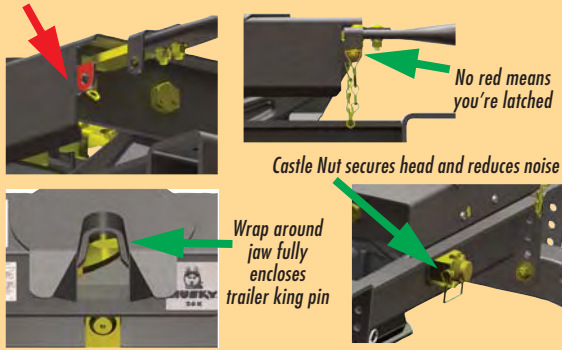

THE NEXT GENERATION OF FIFTH WHEEL HITCHES

A full articulating head allows for the easiest hookups. Articulating heads move with the motion of the trailer, not the tow vehicle, for a smoother ride on rough roads. The locking mechanisms in articulating heads move side to side with the king pin.

Husky Full-Featured Articulating Head Fifth Wheel Hitches (Wrap-Around Jaw)

Product	Use with all Fifth Wheels up to*	Jaw Style	Pop-out Indicator	Fore/Aft Adjustment	Warranty**
Husky 16K W	16,000 lbs.	Wrap	Yes	2 Position	5 years
Husky 26K W	26,000 lbs.	Wrap	Yes	3 Positions	10 years

*Do not exceed vehicle manufacturer weight capacity. **See www.huskytow.com for warranty details.

Fifth Wheel Hitches

HUSKY
TOWING PRODUCTS



NEW 26K EZ ROLLER for 26K W 5th Wheel Hitch









- 26,000 lb. rating
- A full 10" of travel
- No operating handle interference
- Footprint allows for balanced loading
- Superior finish
- Larger handle allows a more ergonomic grip
- Passes SAE J2638
- Includes rail center bolt kit for strength
- Fits all Husky 25K and 26K Fifth Wheel Hitches
- Height adjustments 15-1/4" to 18-5/8" in 3/16" increments



26K W
with Roller

**SILVER SERIES—FEATURING
10 YEAR HUSKY WARRANTY!**

Husky Silver Series Select-A-Hitch, as easy as 1-2-3

HITCH TYPE	STEP 1: HEAD		STEP 2: TOW VEHICLE		STEP 3: BASE RAIL		
	Head + Cross Member (Silver)	+	Short Bed	OR	Long Bed	+	Rail Only (Black)
	Part #		Roller #		Uprights # (Silver)		Part # ⁽¹⁾
HUSKY FULL-FEATURED ARTICULATING HEAD MODELS (WRAP AROUND JAW)							
16K W	 31326	+	 (Black) 07046	OR	 31314	+	 31323
26K W	 31318	+	 (Silver) 31320	OR	 31325	+	 31323

⁽¹⁾ Installation Kits sold separately (see page 717). Husky offers vehicle specific install kits with universal or limited drill installations.



HUSKY
TOWING PRODUCTS

Fifth Wheel Hitches

HITCHES

ELECTRICAL

ACCESSORIES

RUNNING GEAR

PARTS/DISPLAYS

HUSKY INDEX

16,000 lbs. Capacity Fifth Wheel Hitch (Black Series)

Black Series Double Pivoting Fifth Wheel Hitch Head†, 16,000 LBS. Capacity* — Features double pivoting head for easy loading and unloading on uneven ground. • One piece jaw for easy hooking and unhooking of vehicle securely wraps around kingpin, eliminating rattling. • Easy-to-spot king pin placement indicator lets you know when your fifth wheel is properly positioned. • Handle is removable for safety. Positive latch system with dual safety locking devices. • Latch & pin lock for dual safety protection. • 4° angular pivot provides tighter control of tilt to help prevent truck bed damage. • Finished with durable textured powder coated black polyester paint that resists rust and corrosion. • *Base rails required; purchase separately.*



† Husky Fifth Wheel Hitch with double pivoting head allows for detachment of trailer from truck bed without hitch binding when tow vehicle and trailer are parked on uneven terrain. High-impact rubber bumper cushions the pivot movement at the end of travel.

* Under no circumstances do we recommend exceeding the towing vehicle manufacturer's recommended towing capacity.



Note: Always face rail pins outward.

Description	Part #
16K Fifth Wheel Hitch only, without Base Rails	07054
Custom Base Rails (requires Custom Bracket Kit (see page 717) or 31563, below)	31323
Universal Install Kit	31563

Popular Replacement Parts for 5th Wheel Hitches (Black Series)

Most common replacement parts for these fifth wheel hitches.



Description	Part #
Parts for 16K 07054	
Optional Spare Nuts & Bolts Package for 07054	38971
Replacement Handle Assembly only	30532
Replacement Head Assy. for 07054	38746

Description	Part #
Other Popular Replacement 5th Wheel Hitch Parts	
Rail Hitch Pin, 1/2" x 4-1/8" (3-1/2" Usable Length)	37088
Rail Hitch Pin, 1/2" x 2-7/8"	37076
Spring Clip, Bulk	33792

EZ Roller For 5th Wheel Hitch (For Black or Silver Series)

UPGRADE YOUR HUSKY FIFTH WHEEL HITCH WITH AN EZ ROLLER! The EZ Roller is designed for short bed pickups. It enables your hitch the convenience of mobility to allow for better cab clearance for tight maneuvering. The EZ Roller glides backward towards the tailgate of the truck bed approximately 9". Adjustable with the trailer attached. Finished with a durable black polyester paint that resists rust and corrosion. Works only with the appropriate fifth wheel hitch head (not included).

* Under no circumstances do we recommend exceeding the towing vehicle manufacturer's recommended towing capacity.



Description	Part #
EZ Roller Only for 16K Head, w/o Base Rail or Head	07046
Custom Base Rails (requires Custom Bracket Kit (see page 717) or 31563, below)	31323
Universal Install Kit	31563
Replacement Hardware Kit for EZ Roller	38969
Replacement Rectangular Tube Cover for EZ Roller, Bulk	39037

EZ Roller For 5th Wheel Hitch—Complete (Black Series)

EZ ROLLER COMPLETE WITH 5TH WHEEL HITCH HEAD—The Complete EZ Roller Unit has all the features of the EZ Roller above, plus it includes the fifth wheel hitch head. It requires the 31323 Base Rail Kit with either a custom bracket kit or the 31563 Universal Install Kit (order separately). Height adjustment: 14-1/2" to 18-1/16" in 1-3/16" increments. • 9" travel. • Adjustable with trailer attached. • Works with full-size or mini trucks. • Finished with a durable black polyester paint that resists rust and corrosion.

Description	Part #
EZ Roller for 16K Fifth Wheel Hitch	
EZ Roller with 16K Head, w/o Base Rail Kit	07048
Custom Base Rails (requires Custom Bracket Kit (see page 717) or 31563, below)	31323
Universal Install Kit	31563
Replacement Shim to help in installation	30703
Replacement 5th Wheel Handle Assembly only	30532



Base Rails

HUSKY
TOWING PRODUCTS



Base Rails and Bracket Kits

31323 BASE RAIL — For the perfect fit, use the **31323 Base Rail** with one of the the Custom Bracket Kits below to fit your truck to the Husky Fifth Wheel Hitch, EZ Roller, and Gooseneck Hitches. Bracket Kits come with hardware and easy-to-install instructions. **You must order either a custom bracket kit OR the 31563 Universal Base Rails to install the 31323.**

31323

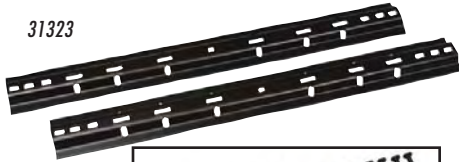

Description	Part #	Price
BASE RAIL KIT — FULL SIZE PICKUPS, 6-1/2' & 8' Bed Lengths		
Custom Base Rails; Includes Two Base Rails only (Bracket Kits sold separately; see below)	31323	
Universal Install Kit; Includes Four Angle Brackets and Associated Hardware in one box for installation on most applications (requires drilling)	31563	
Complete Base Rails for Downsized Pickups (Includes: base rails, brackets and installation hardware)		
Fits Dodge Dakota, 1987-2004, 6-1/2' & 8' Bed, plus Ford Ranger, 1983-2007, 6' & 7' Bed	07045	

BRACKET KITS, REQUIRED FOR USE WITH 31323 BASE RAIL

Year	Make	Pickup Model	Bed L	Attachment Type	Bracket Part #	Price
07-11	Chev/GMC	Silverado & Sierra 1500 New Body (GMT 900)	6-1/2' & 8'	Custom brackets, drilling required	31396	
99-10	Chev/GMC	Silverado & Sierra, All (includes up to 07 Classic) plus 07-09 2500HD & 3500	6-1/2' & 8'	Custom brackets, drilling required	31415	
01-10	Chev/GMC	2500/3500 With or Without Integrated Brake Control Plus 99-07 Classic 1500	6-1/2' & 8'	Custom brackets, drilling required	31397	
11	Chev/GMC	Pickup 2500/3500	6-1/2' & 8'	Custom brackets, No drill (frame) Bolt-on	31852	
11	Chev/GMC	Pickup 2500/3500	6-1/2' & 8'	Custom brackets, drilling required Bolt-on	31853	
88-98	Chev/GMC	C/K Pickup 1500, 88-99 C/K Pickup 2500/3500	6-1/2' & 8'	Custom brackets, drilling required	31402	
73-87	Chev/GMC	Pickup	6-1/2' & 8'	Universal bracket kit, drilling required	31563	
07-08	Dodge	Ram Pickup 1500	6-1/2' & 8'	Custom brackets, drilling required	31565	
07-08	Dodge	Ram Pickup 1500	6-1/2' & 8'	Custom brackets, no drill clamp-on	31413	
09-11	Dodge	Ram Pickup 1500	6-1/2' & 8'	Custom brackets, no drill (frame) clamp-on	31566	
02-06	Dodge	Ram Pickup 1500, plus 06 1500 Mega Cab	6-1/2' & 8'	Custom brackets, drilling required	31565	
03-09	Dodge	Ram Pickup 2500, 3500 (except 3500HD 4WD)	6-1/2' & 8'	Custom brackets, drilling required	31565	
03-11	Dodge	Ram Pickup 2500, 3500	6-1/2' & 8'	Custom brackets, no drill (frame) clamp-on	31413	
02-06	Dodge	Ram Pickup 1500 (Except '06 1500 non-Mega Cab)	6-1/2' & 8'	Custom brackets, no drill, clamp-on	31413	
94-02	Dodge	Ram PU, All (except 2002 1500)	6-1/2' & 8'	Custom brackets, drilling required	31404	
93-Older	Dodge	Ram Pickup	6-1/2' & 8'	Universal bracket kit, drilling required	31563	
04-11	Ford	F-150 (Clamp On) (New Body Style)	6-1/2' & 8'	Custom brackets, no drill, clamp-on	31564	
08-11	Ford	3/4 & 1 ton Pickups	6-1/2' & 8'	Custom brackets, drilling required	31408	
05-10	Ford	F-250/350 plus 08-09 F-450 Super Duty	6-1/2' & 8'	Custom brackets, drilling required	31412	
08-11	Ford	F-250/350/450 Super Duty	6-1/2' & 8'	Custom brackets, drilling required	31408	
99-07	Ford	F-250/350 Super Duty	6-1/2' & 8'	Custom brackets, no drill (frame), bolt-on	31407	
99-04	Ford	F-250/350 Super Duty	6-1/2' & 8'	Four bolt drill. Top frame rail mounting	31405	
99-04	Ford	F-250/350 Super Duty	6-1/2' & 8'	Custom brackets, drilling required	31406	
97-04	Ford	F150 Heritage (old body)	6-1/2' & 8'	Custom brackets, drilling required	31409	
98-Older	Ford	F250HD / F350, plus 96-Older F150 / 250	6-1/2' & 8'	Universal bracket kit, drilling required	31563	
04-09	Nissan	Titan King Cab plus 08-09 Titan Crew Cab Pickup	6-1/2' & 8'	Custom brackets, drilling required	31395	
07-11	Toyota	Tundra Pickup	6-1/2' & 8'	Custom brackets, no drill on frame	31410	
99-06	Toyota	Tundra Pickup	6-1/2' & 8'	Universal bracket kit, drilling required	31563	
		Universal Style, for Older Full Size Pickups	6-1/2' & 8'	Universal bracket kit, drilling required	31563	

Additional Brackets & Hardware	Qty/Hitch	Part #	Price
Custom Bracket Kit for use with 31404 ; Fits Dodge 02-05 Ram PU 1500, 03-05 2500, 6-1/2' & 8' Bed	1	31414	
Straight "L" Brackets	2	05371	
Left and Right Angle Brackets	2	05385	
Offset Angle Brackets	2	05386	
Replacement Bolts, Nuts, Spacers, etc. for 31563 Bracket Kit.	1 box	38968	

Additional Brackets & Hardware	Qty/Hitch	Part #	Price
Adapter Bracket for Dodge Ram Pickup (MUST be used with 31563 Universal Base Rail Kit) (Limited supply)	1 each	05680	
Reinforcement Plate	4 each	37093	
Spline Stud 1/2" x 1-1/2"	8 each	38973	
Center Bolt Kit to use with 20K, 25K? 26K Fifth Wheel Hitches and Rollers (Black Series only)		053362	



Receiver Hitches

HUSKY Class V HD Series Receiver Hitches

Our Super Duty Series Receiver Style Hitches meet your maximum trailer towing needs. Class V rating for this popular hitch is up to 12,000 lbs. ‡ weight carrying and 15,000 lbs. ‡ weight distributing. • Fits Chevy/GMC/Dodge and Ford. • 2-1/2" receiver opening. • Easy to install. • Finish is corrosion resistant powdercoat polyester black paint.

HUSKY Class IV Super-Duty Hitches

Designed to tow up to 10,000 lbs. ‡ weight carrying and up to 12,000 lbs. ‡ weight distributing. • Ideal for full size, long wheel base trucks and SUVs. • Standard 2" receiver. • Finish is corrosion resistant powdercoat polyester black paint. • Easy installation. • Uses many existing holes. *Now you can really maximize the towing capacity of your new full size pickup.*

Class III/IV Receiver Hitches

For use on full size trucks, sport utilities, vans, passenger cars, & motorhomes. Designed for towing heavy trailers. • Class III/IV Receiver Hitches are for towing up to 6,000 lbs. ‡ weight carrying and up to 10,000 lbs. ‡ weight distributing. • Custom fit. • No drilling required on many applications. • Easy to install. • Finish is corrosion resistant powdercoat polyester black paint. • Standard 2" receiver.

‡ Under no circumstances do we recommend exceeding the towing vehicle manufacturer's recommended towing capacity.

Model	SubModel	Year	Receiver III, IV, V		Foot-note	Ø= No Drill	Towing Capacity (lbs. x 1000)		Round Tube	Hitch Style	Install Time (minutes)
			Order No.	Mfr. No.			Weight Carrying	Weight Distributing			
ACURA											
MDX		04-06	31481	82110		Ø	3.5	5	•	CF	30
		01-03	31481	82110			3.5	5	•	CF	30
CHEVROLET											
PICKUP C/K	1500	88-98	08103	81030		Ø	5	10	•	CF	20
	2500	99-00	08103	81030		Ø	5	10	•	CF	20
	3500	99-00	08103	81030		Ø	5	10	•	CF	20
PICKUP C/K	Long & Short Bed, Multi-Fit Hitch	88-98	08227	82270		Ø	5	7.5		MF	45
BLAZER (Downsize)		98-05	08169	81690		Ø	4	6	•	CF	20
SILVERADO (New Body)	1500LD	07-11	082123	82123		Ø	6	10	•	CF	20
	2500/3500HD	07-10	08217	82170		Ø	6	10	•	CF	20
		07-10	31482	82151		Ø	10	12	•	CF	20
SILVERADO CLASSIC	1500LD & 1500HD	99-07	082123	82123		Ø	6	10	•	CF	20
		99-07	31488	82510		Ø	10	12		CF	20
	1500HD only	01-07	08217	82170		Ø	6	10	•	CF	20
		01-07	31482	82151		Ø	10	12	•	CF	20
		01-07	08217	82170		Ø	6	10	•	CF	20
	01-07	31482	82151		Ø	10	12	•	CF	20	
SILVERADO	All, Multi-Fit Hitch	99-07	08227	82270		Ø	5	7.5		MF	45
TRAVERSE		09-11	31486	82541		Ø	4	5	•	CF	25
COLORADO		04-10	31489	82641		Ø	4	6	•	CF	25
EQUINOX		05-11	08254	82540		Ø	4		•	CF	30
CHRYSLER											
TOWN & COUNTRY		08-10	31493	82683	LS	Ø	4	5		CF	20
		08-10	31832	82684		Ø	4	5		CF	20
	w/ Stow & Go Seats	05-07	08277	82770		Ø	3.5	4		CF	20
	w/o Stow & Go Seats	04-07	08218	82180			3.5	5	•	CF	25
		96-03	08218	82180			3.5	5	•	CF	25
VOYAGER		01-03	08218	82180			3.5	5	•	CF	25

Receiver Hitches

HUSKY
TOWING PRODUCTS



Model	SubModel	Year	Receiver III, IV, V		Foot-note	Ø= No Drill	Towing Capacity (lbs. x 1000)		Round Tube	Hitch Style	Install Time (minutes)
			Order No.	Mfr. No.			Weight Carrying	Weight Distributing			
DODGE											
DAKOTA PICKUP		05-10	08280	82800		Ø	5	7.5		CF	25
		87-04	08147	81470	10		5	7.5	•	CF	30
DURANGO		98-03	08160	81600		Ø	5	7.5		CF	25
JOURNEY		09-10	31497	82051	LS	Ø	4			CF	25
RAM PICKUP	DS (New Body) 1500	09-11	31492	82861		Ø	6	12		CF	20
RAM PICKUP	1500 (Old Body)	03-08	31492	82861		Ø	6	12		CF	20
		94-01	08178	81780		Ø	6	10	•	CF	20
	1500 Short Bed	94-01	08227	82270			5	7.5		CF	45
	1500 Long Bed	94-01	08227	82270		Ø	5	7.5		CF	45
		94-02	08178	81780		Ø	6	10	•	CF	20
	2500/3500 Multi-Fit Hitch Short Bed	94-02	08227	82270			5	7.5		CF	45
	2500/3500 Multi-Fit Hitch Long Bed	94-02	08227	82270		Ø	5	7.5		CF	45
RAMCHARGER	All, Multi-Fit Hitch	78-95	08227	82270			5	7.5		MF	45
SPRINTER - 2500	144"/170" WB w/Standard Bumper	07-10	31490	82763		Ø	5	7.5		CF	20
	144"/170" WB w/Step Bumper	07-10	31499	82762		Ø	5	7.5		CF	20
SPRINTER - 3500	170" WB w/Standard Bumper	07-10	31490	82763		Ø	5	7.5		CF	20
	170" WB w/Step Bumper	07-10	31499	82762		Ø	5	7.5		CF	20
FORD											
ECONLINE		92-11	31495	74080			5	10	•	CF	20
RANGER		83-09	31496	81620	LS		4	6	•	CF	25
F-150	New Body	09-11	31491	82843		Ø	6	12		CF	20
		06-08	082842	82842		Ø	6	12		CF	20
	Heritage Models Only	04	08176	81760		Ø	6	10		CF	20
		04	08250	82500		Ø	10	12		CF	25
	STYLESIDE, FLARESIDE	97-03	08176	81760		Ø	6	10		CF	20
		97-03	08250	82500		Ø	10	12		CF	25
	Multi-Fit Hitch	60-03	08227	82270		Ø	5	7.5		MF	45
F-150 SUPERCREW		01-03	08176	81760		Ø	6	10		CF	20
		01-03	08250	82500		Ø	10	12		CF	25
F250 LIGHT DUTY		97-98	08176	81760		Ø	6	10		CF	20
		97-98	08250	82500		Ø	10	12		CF	25
	Multi-Fit Hitch	60-96	08227	82270		Ø	5	7.5		MF	45
F250HD & F350	Multi-Fit Hitch	97-98	08227	82270			5	7.5		MF	45
F250/F350 SUPER DUTY		99-10	08250	82500	47	Ø	10	12		CF	25
		99-11	08176	81760		Ø	6	10		CF	20
	Multi-Fit Hitch	99-09	08227	82270			5	7.5		MF	45
F-SERIES	All, Multi-Fit Hitch	60-96	08227	82270			5	7.5		MF	45
BRONCO	All, Multi-Fit Hitch	76-96	08227	82270			5	7.5		MF	45
ESCAPE	All	05-11	31483	82211		Ø	4	5	•	CF	25
FLEX	No Eco-Boost	09-11	31498	82215		Ø	5		•	CF	35
GMC											
PICKUP, C/K	Long & Short Bed, Multi-Fit Hitch	88-98	08227	82270		Ø	5	7.5		MF	45
SIERRA	All, Multi-Fit Hitch	99-07	08227	82270		Ø	5	7.5		MF	45
SAVANA VAN		96-11	08139	81390		Ø	5	10		CF	20
YUKON		00-06	08199	81990	6	Ø	6	10	•	CF	20
YUKON XL		00-06	08199	81990		Ø	6	10	•	CF	20
CANYON		04-11	31489	82641		Ø	4	6	•	CF	25
HONDA											
PILOT		03-08	31481	82110		Ø	3.5	5	•	CF	30
ODYSSEY		99-11	31485	82400		Ø	3.5	5	•	CF	25

HITCHES

ELECTRICAL

ACCESSORIES

RUNNING GEAR

PARTS/DISPLAYS

HUSKY INDEX



Receiver Hitches

HITCHES

ELECTRICAL

ACCESSORIES

RUNNING GEAR

PARTS/DISPLAYS

HUSKY INDEX

Model	SubModel	Year	Receiver III, IV, V		Foot-note	Ø = No Drill	Towing Capacity (lbs. x 1000)		Round Tube	Hitch Style	Install Time (minutes)
			Order No.	Mfr. No.			Weight Carrying	Weight Distributing			
JEEP											
GRAND CHEROKEE		99-04	08180	81800		Ø	5	8	•	CF	20
LIBERTY		02-07	08223	82230		Ø	3.5	5		CF	20
WRANGLER		07-10	31484	82371		Ø	3.5			CF	20
		97-06	08278	82780		Ø	3.5			CF	25
LEXUS											
RX 330		04-06	31479	81310		Ø	3.5	4	•	CF	25
RX 350		07-09	31479	81310		Ø	3.5	4	•	CF	25
RX 400H		06-09	31479	81310		Ø	3.5	4	•	CF	25
MAZDA											
TRIBUTE		05-11	31483	82211		Ø	4	5	•	CF	25
MERCURY											
MARINER	All	05-10	31483	82211		Ø	4	5	•	CF	25
NISSAN											
FRONTIER		05-11	08125	81250		Ø	5	6		CF	20
TITAN		04-11	08274	82740		Ø	6	10	•	CF	20
PLYMOUTH											
TRAIL DUSTER	All, Multi-Fit Hitch	74-81	08227	82270			5	7.5		MF	45
PONTIAC											
TORRENT		07-09	08254	82540		Ø	4		•	CF	30
SATURN											
VUE	Excl. Redline	02-07	08254	82540		Ø	4			CF	30
TOYOTA											
HIGHLANDER	All Models	08-11	31494	81312		Ø	5	6	•	CF	30
		04-07	31479	81310		Ø	3.5	4	•	CF	25
TACOMA		05-11	08279	82790		Ø	5	6		CF	25
		95-04	08159	81590		Ø	5		•	CF	30
TUNDRA PICKUP		07-11	31480	81881		Ø	6	10	•	CF	25
	All, Multi-Fit Hitch	00-06	08227	82270			5	7.5		MF	45
SIENNA		04-11	08270	82700		Ø	3.5	4	•	CF	20
		06	08254	82540		Ø	4		•	CF	30

Hitch Style: CF = Custom Fit. HD = HD Series. MF = Multi-Fit. Footnotes: 6 = Except with right frame canister. 10 = Without roll pan. 47 = Will not fit with 18" spare.

Universal Step Bumper Hitch

3,500 lbs. † gross weight; 300 lbs. † tongue weight. **07528** is a universal fit flat mounting plate with 4-hole attachment points; requires minimum 4-1/2" deep flat mounting surface. Some drilling required. **07603** attaches to bumper only, and fits older pickups with flat bottom faced step bumper. Includes chain loops.



Description	Part #
Receiver-Style	
2" Rec. Tube for Step Bumper	07528
Flat Mounting Plate	
2" Universal Fit Flat Mounting Plate, 4-Hole Attachment Points	07603

Receiver Tubing with Collar

• 2" I.D. square tube in various lengths for weld-on, custom fabrication installations. • Lightly painted.



Description	Part #
6" Receiver Tube	34902
12" Receiver Tube	34903
24" Receiver Tube	34904
36" Receiver Tube	34905
48" Receiver Tube	34906